

SLQ-QT105 Datasheet

High Purity Milliliter Flow Meter for Hydrocarbons

- Sensitive to low flow rates
- Straight flow channel
- Maximum flows up to 2 ml/s
- Fast measurement response for dosing monitoring
- Super fast sampling speed



1 Product Summary

The SLQ-QT105 Flow Meter offers an exceptional liquid flow sensing performance based on a thermal microsensor technology. It is made for use with hydrocarbon based liquids. The fluidic part of the device is based on just a straight flow path and no moving parts. Due to the short response time the SLQ-QT105 allows to monitor highly dynamic processes like fast dosing operations. In many applications this gives the opportunity to increase process reliability and reduce consumption of precious media.

2 Sensing Performance with Reference Medium Isopropyl Alcohol

In Table 1 the flow meter's performance for use with Isopropyl Alcohol (IPA) is given. For other hydrocarbons the values will be different as the performance depends on the medium used. The repeatability depends on the averaging time of the signal. Longer averaging time leads to better repeatability of the flow measurement (see table 1).

Table 1: Model specific performance of SLQ-QT105 for IPA (all data at 23°C, 1 bar_{abs} unless otherwise noted)

Parameter	Condition	SLQ-QT105	Units
Maximum Flow Rate ^a		2000	µl/s
Repeatability (1σ) (whichever is greater)	0.2 sec averaging time	2	% m.v.
		0.3	% F.S.
Flow Detection Response Time		< 50	ms
Accuracy ^b		10	% m.v.
Response Time On Power-Up		< 120	ms
Optimal heat up time	For constant flow measurement	500 – 1500	ms
Mounting Orientation Sensitivity ^c	For IPA; 23°C	< 5	µl/s
Operating Temperature		+20 ... +25	°C
Ambient storage temperature	(empty flow channel)	-10... +60	°C

^a Medium IPA

^b With IPA, 50 - 2000 µl/s

^c Normal position: Horizontal Flow channel, connector horizontally.

3 Sensing Performance with Other Media but Isopropyl Alcohol

The flow meter's measurement performance for other media but Isopropyl Alcohol (IPA) depends strongly on the properties of the liquid. It is known that the performance for most hydrocarbon based liquids, i.e. solvents and solvent based photoresists, are similar to the performance with IPA, with the exception of the accuracy. The flow meter's calibration is only valid for IPA. For other liquids the repeatability of the measurement is still excellent. It is the user's responsibility to test the flow meter with all liquids that are to be used with the flow meter.

Special care has to be taken with media that contain water. The flow meters maximum flow rate for measuring pure water is 5 ml/min only. For liquids with water content the maximum flow rate will be between 5 ml/min and 120 ml/min depending on the mixture composition.

Table 2: Examples for common media

Medium	Maximum Flow Rate	Units
IPA	2000	μl/s
Ethanol, Methanol, Gasoline	~830	
Acetone	~670	
Diesel, Petroleum, Veg. Oils	1300 (1600)	
Silicon Oil, Ether	< 1600	
Water	85	

3.1 Exchangeability

Every SLQ-QT105 is calibrated for IPA. This makes the flow meters also exchangeable for use with other media, meaning that once the flow meters are characterized for a particular medium the same values can be used for further flow meters but depending on the media variations between flow meters of 6– 20% are typical.

4 Liquid Temperature Management

Due to the microsensors technology used, the amount of thermal energy introduced into the liquid medium is very small. Anyway, it is recommended to avoid heat-up of the liquid in the thermal flow meter, by turning off the micro heater when the liquid is not flowing. For instruction on how to control the sensor's micro heater refer to separate documentation.

When measuring according to the instruction for dosing measurements the heat up behavior of the liquid is given in table 3.

Table 3: Heat-up behavior (for IPA)

Heater Setting	Flow Situation	Examined Waiting Time	Heat up of liquid
Heater off	flow / no flow	unlimited	< 0.3 °C
Heater on	no flow	1 second after heater turned on	< 0.075 °C
Heater on	no flow	2 seconds after heater turned on	< 0.15 °C
Heater on	no flow	> 2 seconds after heater turned on	< additional 0.1°C / second
Heater on	constant flow X ml/min		≈ 0.03 °C / X

5 On-Site Flow Path Cleaning

Due to the thermal measurement principle the flow meter is sensitive to depositions on the inside of the flow meter's flow path made of quartz glass. Especially when changing from one liquid to another, sufficient cleaning procedures have to be performed to avoid non-soluble depositions on the flow channels wall. Inadequate cleaning can lead to an offset and low repeatability together with bad accuracy. The cleaning procedure has to efficiently remove contaminations from the quartz glass surfaces. This is the material which is used for the straight flow channel inside the flow meter.

Any kind of mechanical cleaning has to be avoided. This will easily damage the internal capillary. The exact kind of cleaning procedure depends highly on the specific liquids used before. So is it not possible to give general advice for this.

6 RS485 Interface Specifications

The SLO-QT105 flow sensor offers a RS485 digital interface using Sensirion's RS485 Sensor Cable. With this, power supply and safe operation of multiple devices via one single RS485 bus is possible. A special feature of this RS485 unit is an internal ring buffer allowing to independently record flow rate data for a certain period of time.

Separate documentation is available on request for

- Sensirion RS485 Sensor Cable
- Communication Protocol according to RS485 Sensirion HDLC Standard
- Communication via Sensirion Driver DLL for Windows
- Support Documents for Dosing Monitoring

Table 4: Specifications of Digital Interface

Parameter	SLO-QT105	
Digital Interface	RS485	
Power Supply DC, VDD	4.5 – 5.5	V
Operating Current	tbd	mA

Ground of power supply and ground of the communication system have to be connected.

6.1 Overvoltage Protection, ESD, EMI

6.1.1 PELV Device

The SLO-QT105 flow meter is classified as a PELV (Protected extra-low voltage) system according to IEC 61140. PELV system are defined as an: "electrical system in which the voltage cannot exceed ELV (extra-low voltage, an ELV circuit is defined as one in which the electrical potential of any conductor against earth (ground) is not more than 120 volts for direct current)) under normal conditions, and under single-fault conditions, except earth faults in other circuits".

6.1.2 EMI

The flow meter complies with EN55011-1. This does only concern the flow meters body and not the cable. It is the task of the user to confirm that the electromagnetic radiation of the cable and communication setup satisfies his demands.

6.2 Mechanical Specifications and Pressure Rating

Table 5: Mechanical Specifications and Pressure Rating

Parameter	SLO-QT105
Fluid Connector Standard (Fittings)	Super 300 Type Pillar Fitting 4x3mm
Overpressure Resistance	3 bar / 45 psi
Pressure drop at 120 ml/min IPA, 25°C,	< 10 mbar
Flow Channel, Inner Diameter	1.9 mm
Protection Class	IP32
Total Mass	~ 45 g

6.3 Wetted Parts

Table 6: Wetted Materials

Part	Material
Ports	PCTFE
Sealing part	PFA
Capillary	Quartz

6.4 Protection against Aggressive Environment

To allow visual detection of leakage inside the measurement cell, the sensor is equipped with drainage holes in the bottom plate. Through the drainage holes the measurement cell is exposed to the sensor's environment. Liquid should never enter the drainage holes; this can lead to damage of the sensor. Aggressive vapors in the environment of the sensor can influence measurement performance and damage the sensor.

7 Physical Dimensions and Fluidic Connections

The flow meter is equipped with Super 300 Type Pillar Fittings for 3 mm ID / 4 mm OD tubing.

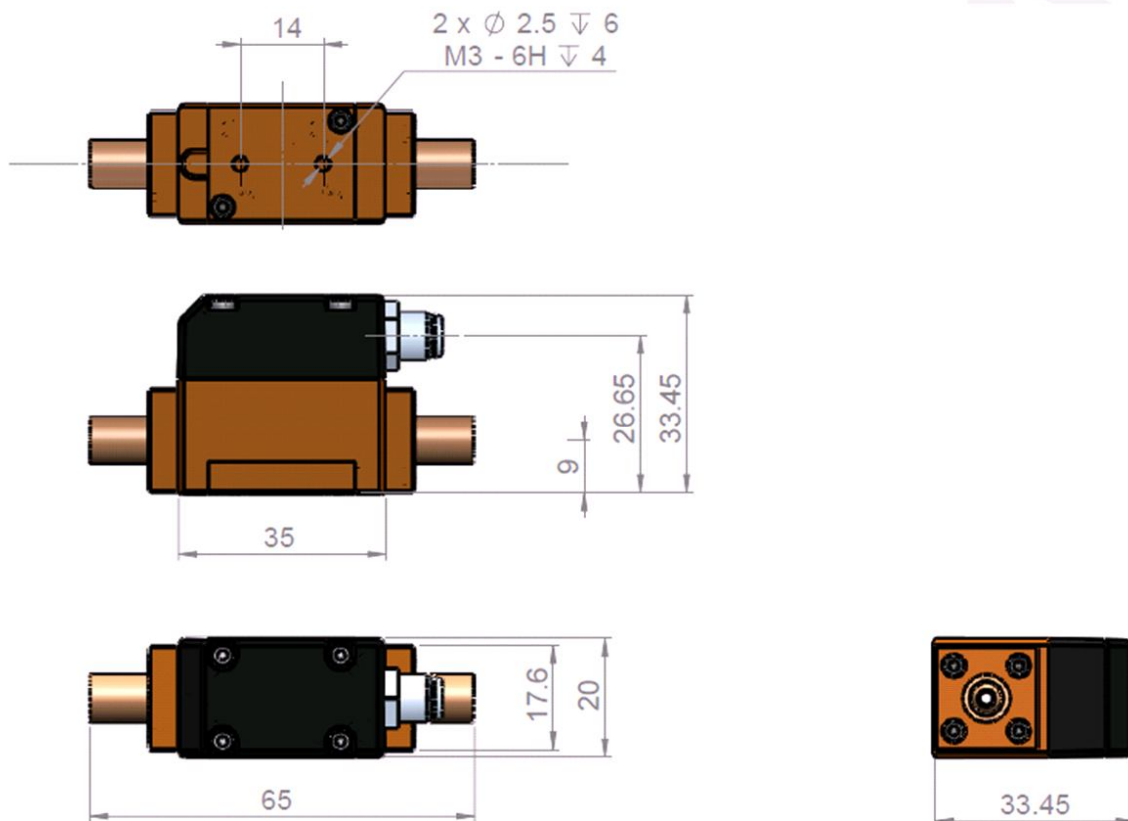

8 Flow Meter Lifetime

The expected lifetime of the flow meter is 3 years of constant operation.

Under the conditions that the sensor is used:

- With non-depositing and non-abrasive liquids
- In a clean and dry environment free of aggressive vapours
- In an environment with constant temperature within the range specified in chapter 2.

- In compliance with all other handling instructions.

The expected lifetime is defined as the mean time between failures.

Failures are defined as:

- Reduction of sensing repeatability (as defined in chapter 9) below the specified limits.
- Electrical failure as: digital communication impossible or not complying with the expected behaviour.

9 Appendix A: Measurement of Dosing Processes

The accurate and/or repeatable measurement of dosing processes with photoresist using the flow meter SLQ-QT105 requires active and precise control of the timing between turning on the flow meter's heater and the start of the dosing process. The ideal waiting time between heater on and pump start depends on the liquid and the details of the application, however it has been determined that a waiting time of 1 second is the ideal value for first tests. For best repeatability of the measurement the waiting time must not vary from measurement to measurement.

For all repeatability measurements of dosing processes it is assumed that the repeated dispense flow profiles are approximately identical and have approximately the shape of a step function. The repeatability will be reduced if this is not the case.

The best repeatability can only be guaranteed at full speed measurement: There must be no delay between the single measurements.

The repeatability^a is defined as the deviation of the integrals over time

- of identical dosing processes,
- without changes in the chemical composition of the liquid measured,
- without changes in temperature or pressure of the liquid, or the environment,
- without changes in orientation or position of the flow meter, the system or the systems components,
- without changes of or on the reference device (pump, scale, flow meter, measuring container),
- at different times within a time window of 24 hours,
- under the condition that the system is properly cleaned immediately after stop of operation.

9.1 Standard Instructions for Best Measurement

The following are the standard instructions for the measurement of a dosing process. If you follow these instructions a measurement repeatability of 2.00% (3σ of consecutive dosing measurements, see detailed explanation above) is achieved. If you need to deviate from the numbers in these standard instructions consult the specific application note to understand the influence of the changes on the flow meter's repeatability.

Initialization Procedure:

- After the flow meter is powered on, do a dummy flow measurement (single measurement point is sufficient; it is not necessary to turn on the heater for this) to initialize the sensor
- Wait at least 30 sec. before the first dosing measurement; after the 30 seconds the sensor has reached internal equilibrium and is ready for most repeatable measurement
- Repeat this every time the flow meter was powered off

Measurement:

- Turn the heater on 1 sec before the pump starts
- Do the measurement in the continuous measurement mode of the RS485 Sensor Cable and allow no "holes" in the stream by retrieving measurement data before buffer is full
- Flow rates between: 5 – 80 ml/min
- Duration of dispense process: 0.7 – 3 seconds

^a The repeatability only refers to the sensors repeatability under the assumption that the reference device is perfect.

- Turn the heater off at the latest 0.5 sec after the pump stopped pumping
- Wait at least 10 sec before turning the heater on again for the measurement of the next dosing

Best repeatability between measurements can only be achieved without altering the system in between measurements. No moving, taking tubing off, changes in temperature, etc.
Please see the extensive explanation in the application note.

9.2 Initialization sequence before first dosing measurement

For measurements with highest repeatability it is necessary to initialize the flow meter and allow sufficient warm-up time before the first measurement of a dosing process. After the power is turned on it is necessary to make a single initialization measurement with the flow meter (turning on the heater or pumping liquid is not necessary). The recommended waiting time before the first measurement after this priming measurement is 30 sec. There is no maximum waiting time before the first measurement.

9.3 Ambient and liquid temperature

Variations in the liquid, the ambient temperature and the difference between them influence the measurement repeatability. For best measurement repeatability the ambient and the liquid temperature should be maintained at an identical and stable temperature level close to room temperature.

Important Notices

Warning, personal injury

Do not use this product as safety or emergency stop devices or in any other application where failure of the product could result in personal injury. Do not use this product for applications other than its intended and authorized use. Before installing, handling, using or servicing this product, please consult the data sheet and application notes. Failure to comply with these instructions could result in death or serious injury.

If the Buyer shall purchase or use SENSIRION products for any unintended or unauthorized application, Buyer shall defend, indemnify and hold harmless SENSIRION and its officers, employees, subsidiaries, affiliates and distributors against all claims, costs, damages and expenses, and reasonable attorney fees arising out of, directly or indirectly, any claim of personal injury or death associated with such unintended or unauthorized use, even if SENSIRION shall be allegedly negligent with respect to the design or the manufacture of the product.

ESD Precautions

The inherent design of this component causes it to be sensitive to electrostatic discharge (ESD). To prevent ESD-induced damage and/or degradation, take customary and statutory ESD precautions when handling this product.

Warranty

SENSIRION warrants solely to the original purchaser of this product for a period of 12 months (one year) from the date of delivery that this product shall be of the quality, material and workmanship defined in SENSIRION's published specifications of the product. Within such period, if proven to be defective, SENSIRION shall repair and/or replace this product, in SENSIRION's discretion, free of charge to the Buyer, provided that:

- notice in writing describing the defects shall be given to SENSIRION within fourteen (14) days after their appearance;
- such defects shall be found, to SENSIRION's reasonable satisfaction, to have arisen from SENSIRION's faulty design, material, or workmanship;
- the defective product shall be returned to SENSIRION's factory at the Buyer's expense; and
- the warranty period for any repaired or replaced product shall be limited to the unexpired portion of the original period.

This warranty does not apply to any equipment which has not been installed and used within the specifications recommended by SENSIRION for the intended and proper use of the equipment. EXCEPT FOR THE WARRANTIES EXPRESSLY SET FORTH HEREIN, SENSIRION MAKES NO WARRANTIES, EITHER EXPRESS OR IMPLIED, WITH RESPECT TO THE PRODUCT. ANY AND ALL WARRANTIES, INCLUDING WITHOUT LIMITATION, WARRANTIES OF MERCHANTABILITY OR FITNESS FOR A PARTICULAR PURPOSE, ARE EXPRESSLY EXCLUDED AND DECLINED.

SENSIRION is only liable for defects of this product arising under the conditions of operation provided for in the data sheet and proper use of the goods. SENSIRION explicitly disclaims all warranties, express or implied, for any period during which the goods are operated or stored not in accordance with the technical specifications.

SENSIRION does not assume any liability arising out of any application or use of any product or circuit and specifically disclaims any and all liability, including without limitation consequential or incidental damages. All operating parameters, including without limitation recommended parameters, must be validated for each customer's applications by customer's technical experts. Recommended parameters can and do vary in different applications.

SENSIRION reserves the right, without further notice, (i) to change the product specifications and/or the information in this document and (ii) to improve reliability, functions and design of this product.

Copyright© 2001-2011, SENSIRION.
CMOSens® is a trademark of Sensirion
All rights reserved.

RoHS and WEEE Statement

The SLQ product family complies with requirements of the following directives:

- EU Directive 2002/96/EC on waste electrical and electronic equipment (**WEEE**), OJ13.02.2003; esp. its Article 6 (1) with Annex II.
- EU Directive 2002/95/EC on the restriction of the use of certain hazardous substances in electrical and electronic equipment (**RoHS**), OJ 13.02.2003; esp. its Article 4.

Headquarter and Sales Office

SENSIRION AG
Laubisruetistr. 50
CH-8712 Staefa ZH
Switzerland

Phone: +41 44 306 40 00
Fax: +41 44 306 40 30
info@sensirion.com
<http://www.sensirion.com>

Sensirion Korea Co. Ltd.
#1011 Indeokwon Seongji Starwith,
Gwangyang-Dong, 954-6 Anyang-Si,
Gyeonggi-Do, South Korea
Zip Code: 461-060

Phone: +82 31 345 0031 3
Fax: +82 31 345 0034
info@sensirion.co.kr
<http://www.sensirion.co.kr>

SENSIRION Inc.
Westlake Pl. Ctr. I, suite 204
2801 Townsgate Road
Westlake Village, CA 91361
USA

Phone: +1 805 409 4900
Fax: +1 805 435 0467
michael.karst@sensirion.com
<http://www.sensirion.com>

SENSIRION China Co. Ltd.
Room 2411, Main Tower
Jin Zhong Huan Business Building,
Futian District, Shenzhen, PR China
Postal Code 518048

Phone: +86 755 8252 1501
Fax: +86 755 8252 1580
info@sensirion.com.cn
<http://www.sensirion.com.cn>

SENSIRION Japan
Sensirion Japan Co. Ltd.
Shinagawa Station Bldg. 7F
4-23-5 Takanawa
Minato-ku, Tokyo, Japan

Phone: +81 3-3444-4940
Fax: +81 3-3444-4939
info@sensirion.co.jp
<http://www.sensirion.co.jp>

Find your local representative at: <http://www.sensirion.com/rep>